



Standard / FreeAccess for more payload

Bär Cargolift – Lifting Performance.

**BÄR**  
Cargolift®

## Bär Cargolift Standard / FreeAccess Built for payload-optimised distribution transport



Open, closed, up, down – these options can be used to define the requirements on a taillift. After all, not every user intends to load five fully packed trolleys at the same time. Loading two trolleys on a platform in standard height is preferable. Or one pallet with a forklift. So much the better, when the remaining payload of the carrier vehicle allows for additional goods.

Therefore Bär offers for the low and medium payload market segment relatively low platforms and for standardised bodies the light, yet sturdy Standard / FreeAccess Cargolifts. The key factor is the 2=4 technology as well as the further weight-optimised development of the proven S4 products. Because stable and at the same time light Cargolifts are the ideal companions for the light vehicle class.

# Bär Cargolift Standard / FreeAccess

## More payload for light to medium vehicle classes



### 2=4 – How can one lifting and tilting cylinder be enough?

In addition to the powerful cylinder, Standard S2 / FreeAccess A2L Cargolifts have an equalisation mechanism in the lifting arm. With S2 and A2L Cargolifts with an under run bar that moves with the lift – BC 750 S2L/S / A2L and BC 1000 S2 – the transmission of force takes place over the equalisation mechanism and the under run bar, which deforms elastically. In this manner, compensation can be made for the asymmetry determined by the system.

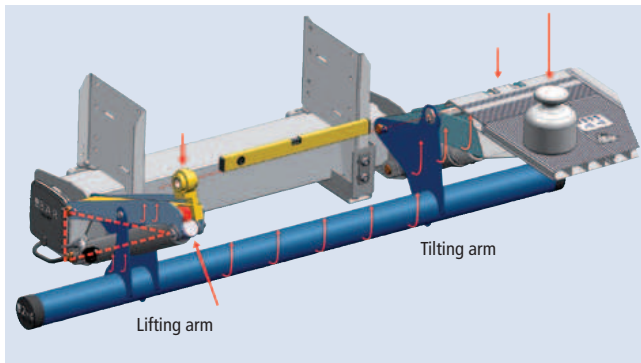

Adjustment mechanism and force transmission for Standard S2 / A2L Cargolifts with movable under run bar

### The light to medium vehicle class

Transporters with a permissible total gross weight of up to 6.5 t have a number of different chassis. They are usually fitted with Cargolifts with a load capacity of 750 kg. Bär Cargolift offers the following for this segment:

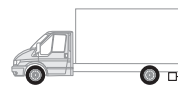

S2L/S / A2L with an under run bar that moves with the lift  
S4 with a fixed under run bar



A2L with a foldable FreeAccess platform

The payload-optimised Standard S2 / S4L Cargolifts with a load capacity of 1000 kg and 1500 kg are available for medium-weight trucks with a permissible total gross weight of up to 18 t:



S2 / S4L for medium-weight trucks

Standard / FreeAccess Cargolifts are designed to accommodate these loads in consideration of the platform height.

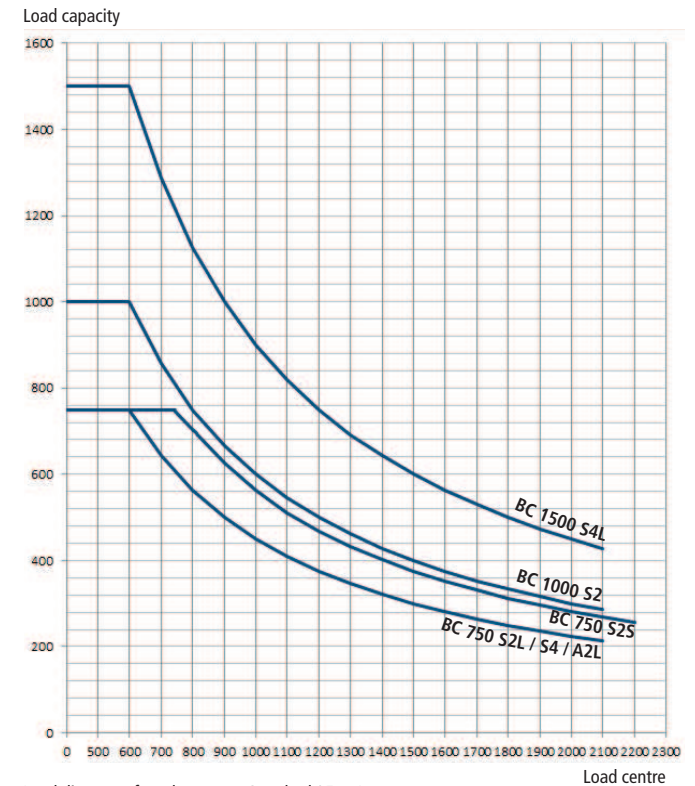

Load diagram of product group Standard / FreeAccess



Website with product movie



# Bär Cargolift Standard S2 / S4L BC 1000 S2 – When every kilo counts



Thanks to the low weight, starting at 291 kg, the BC 1000 S2 assures a positive payload balance. Two trolleys or one pallet can be loaded and unloaded quickly and easily with a pallet truck. This Cargolift also offers the well-known service-friendly and low-maintenance features.

Carrier vehicle	GVW/t min.	GVW/t max.
Truck	6,0 t	8,6 t

Load capacity	Load centre	Load moment
1000 kg	600 mm	6,0 kNm

### Aluminium platform

Platform system	Height	Width
BAplan45VLL	1610-2110 mm	2480 / 2520-2560 mm

### Weight with platform width 2520 mm

Platform height	Weight
1610 mm	281 kg
1810 mm	291 kg

The weight includes the standard scope of supply with mounting material, cables and under run bar.

### Technical data

The following drawing shows installation on U-profile frames. Other frame profiles (e.g. hat profile) may require installation adapters (optional) – see vehicle connection equipment.

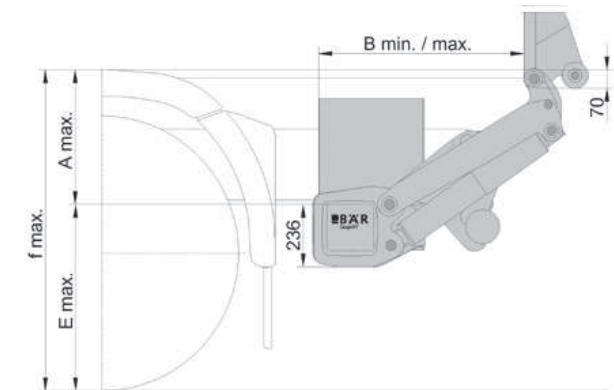

<b>Arm length</b>	<b>700 mm</b>
Lifting height $f_{max}$	1228 mm
Mass $A_{max}$	555 mm
Mass $E_{min}$ beladen	415 mm
Mass $E_{max}$	637 mm
Clearance $B_{min}$	720 mm
Clearance $B_{max}$	850 mm

Valid for vehicles from 8 t gross vehicle weight.

See standardised fitment drawing for fitment details and other carrier vehicles.

# Bär Cargolift Standard S2 / S4L Equipment



## Lifting unit



**Cathodic dip coating** (RAL 9005 - standard) of all steel parts as long-term anti-corrosive protection with out additional top coat. With frequent cleaning of the vehicle, **cathodic dip coating + powder coating** (optional) in RAL colour of your choice.

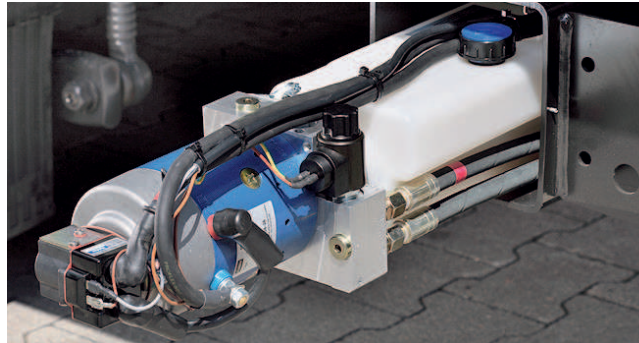

**Power pack** and **control unit** are safely protected in the beam (standard). Motor with thermal circuit breaker protecting against overheating and fire. Simple **emergency operation** of the four basic functions by pushbutton.



Standard **hydraulic oil** requires annual oil change before the winter. For longer oil change interval (every 3 years) as well as for use at low temperatures of up to -45°C: Biodegradable **Syntofluid oil** (option).



Hydraulic cylinder with **protective tube** or **bellow** (standard) as protection from stone chipping and corrosion. Consistently fast, motorised opening by means of double-action tilting cylinders – even in winter.

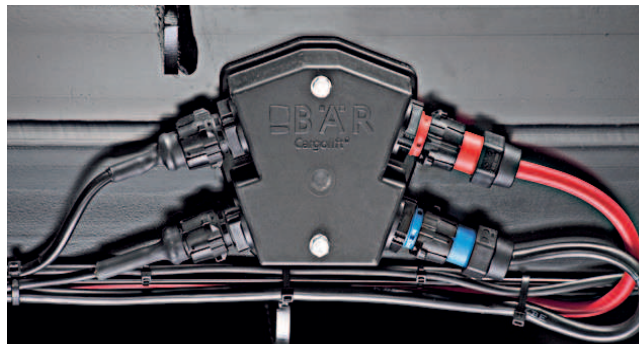

**VDHH electrical interface** (standard) for simple electrical connection.



**Ground rollers** (standard) protect the platform from mechanical abrasion with ground contact.



# Bär Cargolift Standard S2 / S4L Equipment



## Platform



Natural **aluminium** rear platform side (standard) or powder-coated in RAL colour of your choice (option) and **anodised** platform (option) available.

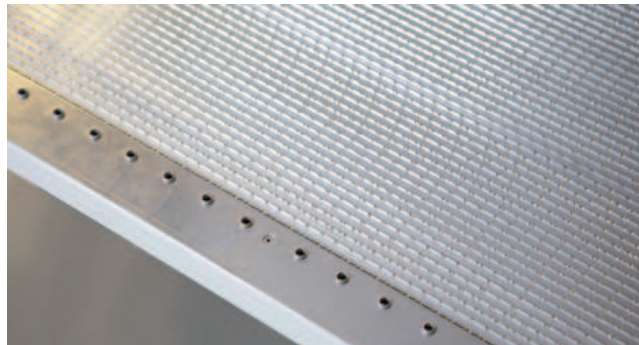

More safety and more traction on the platform with the **TracGrip** and **SideGrip** anti-slip platform surfaces (standard, R11) – even with wet surface. **TracGrip Plus** is optionally available with increased R13 anti-slip resistance.

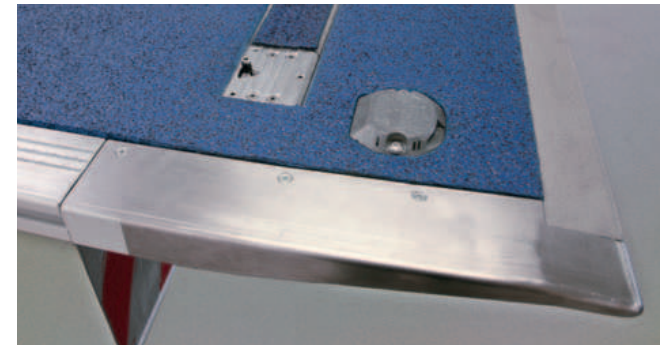

Bär **RamGuard** (option) made of stainless steel for protection of platform corners during ramp use.



Durable **CargoFlash** LED flashing light (standard) with high light intensity and very good sidewise emission with low current consumption.



Bär **SilentGrip** (option, R11) for increased noise insulation during night-time or morning deliveries in residential areas.

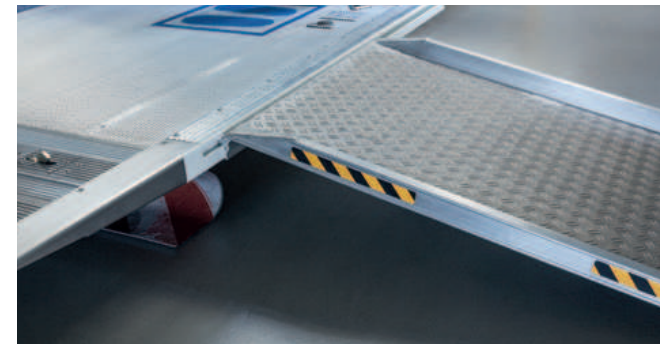

**Platform edging** (option) for infinitely variable attachment of a **side loading ramp** (option) available without track guiding (length 1000 mm; available widths 600 / 734 / 845 mm).

# Bär Cargolift Standard S2 / S4L Equipment



## Platform

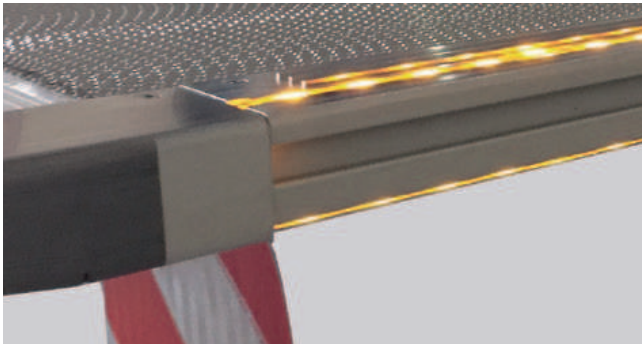

**NightGuide** (option) for maximum visibility. LED strips integrated on both sides at the top and bottom in the platform edging for side loading ramp. Available in 24V for BAplan45VLL height 1,610-2,410 mm.

## Platform – trolley stops (option)

Bär Cargolift offers various **trolley stops** depending on the platform system which is in use. All trolley stops are distinguished by the highest roll-over resistance thanks to a double floor. Operating levers are always outside of the operating range.

For Standard S2 Cargolifts, Bär offers the **trolley stops 2rd and 2ad**, which enable two switching positions by means of operating lever.

Position (1) - Loading - flap opens automatically after being driven over with trolleys

Position (2) - Unloading - flap locks after tramping down

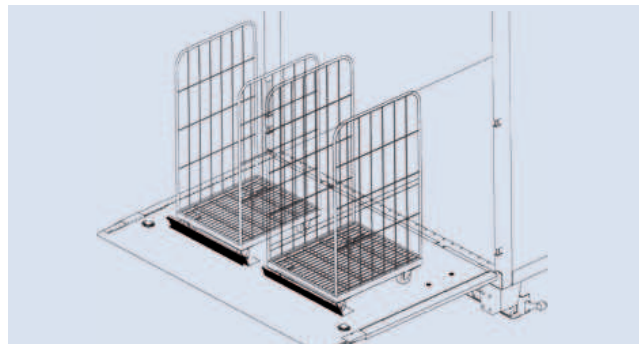

**Trolley stops 2rd and 2ad** enable the simultaneous transport of two trolleys. The trolley stop flaps open individually.

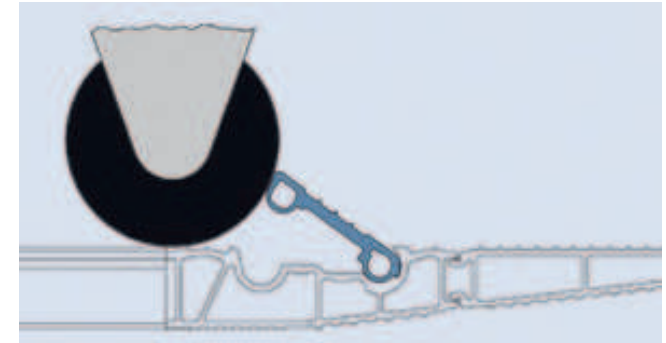

**Trolley stop rd** as a barrier for rollers with an opening angle of 43° for roller diameter up to 110 mm. Flap width: 750 mm with min. platform width of 1950 / 2300 mm.

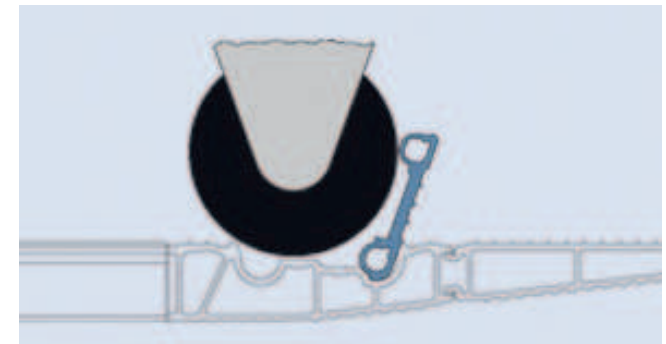

**Trolley stop ad** as a recess for rollers with an opening angle of 110° for roller diameter up to 200 mm. Flap width: 750 mm with min. platform width of 1950 / 2300 mm.

# Bär Cargolift Standard S2 / S4L Equipment



## Platform



**CargoSeal** sealing system (option) for reliable rear end closure with body-closing platform.

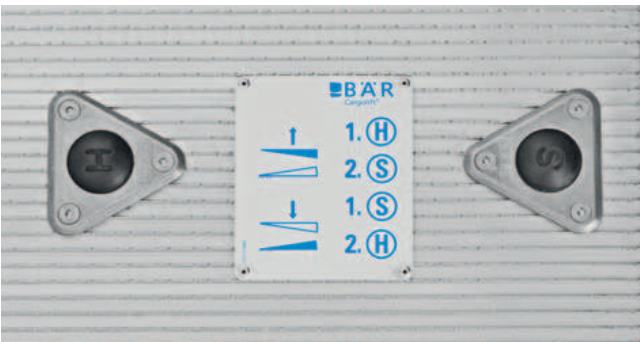

Bär **foot control** (standard) offers simple operation by means of two foot switches in addition to a safe location.

## Control elements



**Control box** (standard S2, option S4L) for operation of four basic functions of the Cargolift.



**Bär Control EVO** (standard S4L, option S2) is intuitive in use, durably constructed and can be easily operated with gloves thanks to the vertically and horizontally operating joysticks. Platform tilt angle can be saved with the right control lever.



**External electrical key switch** (option) for mounting on control box holder. Prevents any undesired operation as an alternative to the SwitchKey.



**SwitchKey** (option for Bär Control EVO) enables the Cargolift to be switched on and off with the control lever, thus preventing any undesired operation.



# Bär Cargolift Standard S2 / S4L Equipment



## Control elements



**Pushbutton plate 3+1** (option) for mounting outside in the body wall.

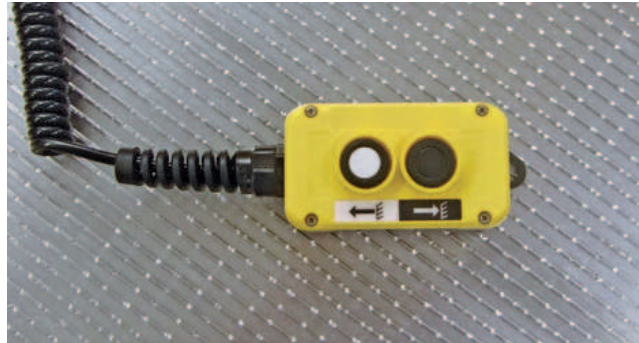

**Wander lead** (option) with two functions incl. platform marking for the assigned operating position. Socket for wander lead pre-fitted on the control box or for mounting in the body.



**Pushbutton plate with 2 functions** (option) for fitment inside the body.



**Bär SmartControl Basic** (option) for CE-compliant operation of all four basic functions by radio.



**Bär SmartControl Plus with docking station** (option) incl. remote control for recharging the accumulators (in place of batteries). Cabin switch can be operated via radio.



**Bär SmartControl cabin control** (option) for control of the Cargolift from the cabin by Bär SmartControl Plus with docking station. See technologies.

# Bär Cargolift Standard S2 / S4L Equipment



## Vehicle connection

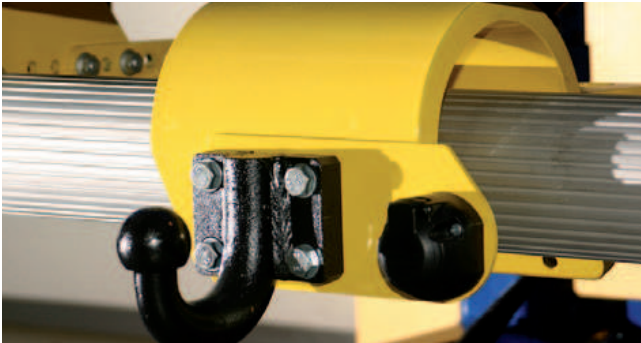

**Towing bracket for ball coupling** (option BC 1000 S2) with European type approval for the parts (parts ABE), D-value 26.9 kN, drawbar load max. 250 kg, weight approx. 45 kg. Advance electrical preparation required on the vehicle! **Ball coupling** optionally available.



**Towing bracket for ball coupling** (option BC 1500 S4L) with European type approval for the parts (parts ABE), D-value 29 kN, max. support load 350 kg, weight approx. 20 kg. Advance electrical preparation required on the vehicle! **Ball coupling** optionally available.

Calculation of the maximum admissible trailer load of the towing bracket:

$$\text{trailer load in t} = \frac{\text{D-value in kN} \times \text{GVW vehicle in t}}{(9,81 \text{ m/s}^2 \times \text{GVW vehicle in t}) - \text{D-value in kN}}$$

In case the carrier vehicle or the ball coupling lead to a lower admissible trailer load, the lowest value is determining.

# Bär Cargolift – Lifting Performance.

The world of transport and logistics is becoming more and more competitive and complex. In order to work successfully in this business, customer oriented solutions with maximum efficiency are required. And last but not least high performance tail lifts.

Bär considers the tail lift as an integral part of an overall system which is being optimized user specifically to maximum performance. Only with a deep understanding of the various transportation tasks an ideal product solution can be created.

The core competence of Bär Cargolift is the continuous enhancement of the performance of tail lifts.

The customer of Bär Cargolift can be sure to receive a solution that supports his work in an optimal way. He gets supported in all phases of the product life cycle from ordering to mounting and from handling to service – based on partnership.

Bär Cargolift has shaped the industry over decades with innovative solutions. Solid technology that can be used easily and safely has created the decisive advance versus the competition.

## Bär Cargolift – Lifting Performance.



Find out more about “Bär Cargolift – Lifting Performance. Since 1981.” – the family business, its innovations and its continuous development at: [www.lifting-performance.com](http://www.lifting-performance.com)



Bär Cargolifts comply with the CE-Norm



Gerd Bär GmbH · Industriegebiet Böllinger Höfe · Pfaffenstraße 7 · D 74078 Heilbronn  
Fon +49 7131 2877-992 · Fax +49 7131 2877-912 · vk@baer-cargolift.de · www.baer-cargolift.com