

Falt



Bär Cargolift – Lifting Performance.

 **BÄR**
Cargolift®

Bär Cargolift Falt Ideal for deep-freeze bodies and for ramp loading



Do you often require free access to the doors, such as when loading and unloading on a ramp? Would a standard platform be disruptive in vehicle use? Then Bär Cargolift Falt is your solution for loading tasks.

In driving position the Bär Cargolift Falt folds down under the vehicle floor. This enables non-restrictive ramp loading. If the Cargolift is needed, the command "lower" sets up the platform package mechanically, so that the user can then unfold it manually. The folding process is thereby facilitated with a spring assistance.

With frequent loading and unloading on a hillside, Bär recommends version F4: While F2 Cargolifts only have two lifting cylinders, the two additional tilting cylinders of the F4 Cargolift enable tilting adjustment at any height. This increases safety and comfort when loading.

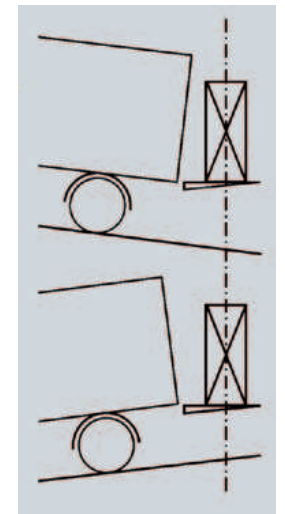

Bär Cargolift Falt

For loading work as necessary



Falt Cargolifts are designed to accommodate these loads in consideration of the platform height.

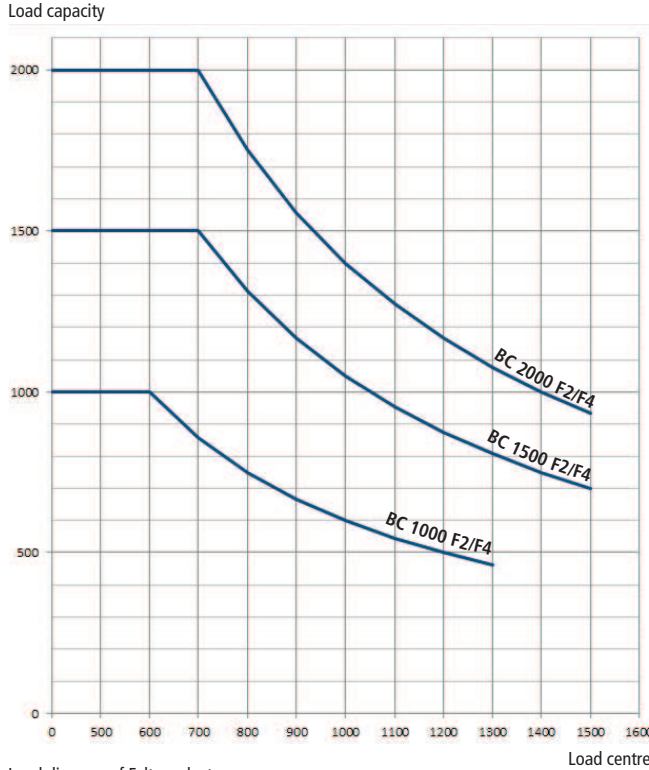

Website with product movie

EN_BC_PORTFOLIO
Techn. modifications subject to modification. 01/23

Bär Cargolift Falt

BC 1000 F2/F4 – The simple and flexible alternative



The manually unfolding BC 1000 F is a favourite solution for trolley transport with frequent loading and unloading at ramps. When at the ramp, this Cargolift disappears out of sight under the vehicle. When needed, however, it is quickly available for use.

Carrier vehicle	GVW/t min.	GVW/t max.
Truck	6,0 t	18,0 t
Trailer	6,0 t	18,0 t

Load capacity	Load centre	Load moment
1000 kg	600 mm	6,0 kNm

Aluminium platform

Platform system	Height	Width
BAfalt45VLL	1210 / 1310 mm	2250 / 2480 mm

Platform width of 2250 mm requires a minimum body width of 2500 mm.

Weight with platform width 2250 mm

Platform height	Weight F2	Weight F4
1210 mm	342 kg	365 kg
1310 mm	347 kg	370 kg

The weight includes the standard scope of supply with mounting material, cables and under run bar.

Technical data

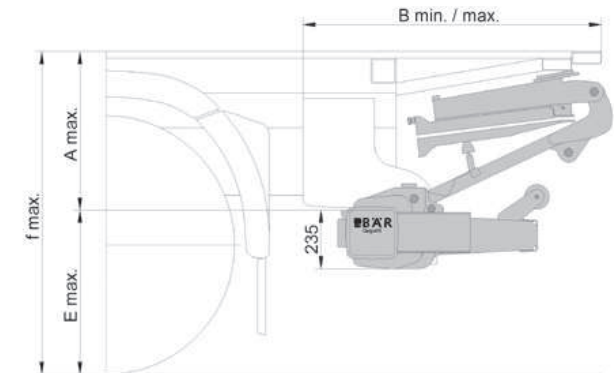

Platform height	1210 mm	1310 mm
Arm length	800 mm	800 mm
Lifting height* f_{min}	985 mm	1035 mm
Lifting height* f_{max}	1390 mm	1390 mm
Mass A_{max}	655 mm	655 mm
Mass E_{max}	635 mm	635 mm
Clearance B_{min}	1020 mm	1020 mm
Clearance B_{max}	1110 mm	1110 mm

*+ 50 with insulated floor

Valid for vehicles from 8 t gross vehicle weight with hydraulic, pneumatic or automatic suspension.

See standardised fitment drawing for fitment details and other carrier vehicles.

Thanks to its design, the structure of the body floor and the insulation value of the refrigerated body are maintained.

Bär Cargolift Falt

BC 1500 F2/F4 – Simple handling with solid loading capacity



With manual unfolding with compact platform dimensions, the BC 1500 F offers a load capacity of 1500 kg and aluminium platforms with height of up to 1510 mm. Unlike F2 variants, it offers tilting compensation at every height by means of two tilting cylinders. In addition to user convenience, also safety is increased.

Carrier vehicle	GVW/t min.	GVW/t max.
Truck	8,0 t	40,0 t
Trailer	8,0 t	40,0 t

Load capacity	Load centre	Load moment
1500 kg	700 mm	10,5 kNm

Aluminium platform

Platform system	Height	Width
BAfalt45VLL	1310 / 1510 mm	2250 / 2480 mm

Platform width of 2250 mm requires a minimum body width of 2500 mm.

Weight with platform width 2250 mm

Platform height	Weight F2	Weight F4
1310 mm	485 kg	508 kg
1510 mm	491 kg	514 kg

The weight includes the standard scope of supply with mounting material, cables and under run bar.

Technical data

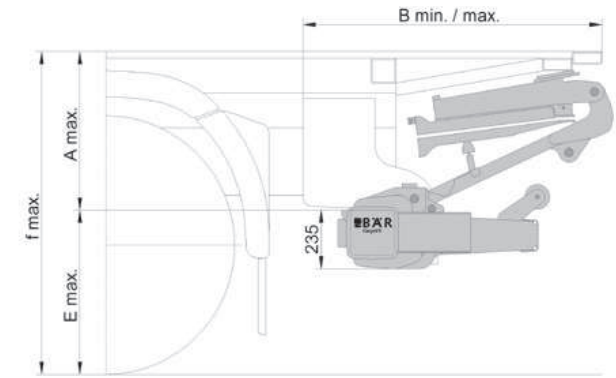

Platform height	1310 mm		1510 mm	
	Arm length	900 mm	1000 mm	900 mm
Lifting height* f_{min}	1050 mm	1050 mm	1140 mm	1140 mm
Lifting height* f_{max}	1405 mm	1485 mm	1405 mm	1485 mm
Mass A_{max}	795 mm	875 mm	795 mm	875 mm
Mass E_{max}	610 mm	610 mm	610 mm	610 mm
Clearance B_{min}	1050 mm	1115 mm	1180 mm	1115 mm
Clearance B_{max}	1215 mm	1335 mm	1215 mm	1335 mm

*+ 50 with insulated floor

Valid for vehicles from 8 t gross vehicle weight with hydraulic, pneumatic or automatic suspension.

See standardised fitment drawing for fitment details and other carrier vehicles.

Thanks to its design, the structure of the body floor and the insulation value of the refrigerated body are maintained.

Patented.

Bär Cargolift Falt

BC 2000 F2/F4 – Simple, flexible, with tilting compensation



The BC 2000 F is also characterised by a load capacity of 2000 kg and platforms with a height of up to 1510 mm. Like all Falt Cargolifts, the BC 2000 F also remains out of sight below the vehicle while at a ramp and quickly can be ready for use on demand.

Carrier vehicle	GVW/t min.	GVW/t max.
Truck	8,0 t	40,0 t
Trailer	8,0 t	40,0 t

Load capacity	Load centre	Load moment
2000 kg	700 mm	14,0 kNm

Aluminium platform

Platform system	Height	Width
BAfalt45VLL	1310 / 1510 mm	2250 / 2480 mm

Platform width of 2250 mm requires a minimum body width of 2500 mm.

Weight with platform width 2250 mm

Platform height	Weight F2	Weight F4
1310 mm	508 kg	531 kg
1510 mm	514 kg	537 kg

The weight includes the standard scope of supply with mounting material, cables and under run bar.

Technical data

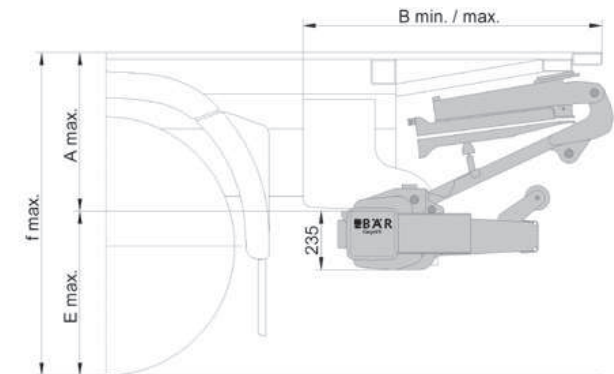

Platform height	1310 mm		1510 mm	
	900 mm	1000 mm	900 mm	1000 mm
Arm length	900 mm	1000 mm	900 mm	1000 mm
Lifting height* f_{min}	1050 mm	1050 mm	1140 mm	1140 mm
Lifting height* f_{max}	1405 mm	1485 mm	1405 mm	1485 mm
Mass A_{max}	795 mm	875 mm	795 mm	875 mm
Mass E_{max}	610 mm	610 mm	610 mm	610 mm
Clearance B_{min}	1050 mm	1115 mm	1180 mm	1115 mm
Clearance B_{max}	1215 mm	1335 mm	1215 mm	1335 mm

*+ 50 with insulated floor

Valid for vehicles from 8 t gross vehicle weight with hydraulic, pneumatic or automatic suspension.

See standardised fitment drawing for fitment details and other carrier vehicles.

Thanks to its design, the structure of the body floor and the insulation value of the refrigerated body are maintained.

Patented.

Bär Cargolift Falt Equipment



Lifting unit



Cathodic dip coating (RAL 9005 – standard) of all steel parts as long-term anti-corrosive protection with out additional top coat. With frequent cleaning of the vehicle, **cathodic dip coating + powder coating** (optional) in RAL colour of your choice.



Hydraulic cylinder with **protective tube** or **bellow** (standard) as protection from stone chipping and corrosion. Consistently fast, motorised opening by means of double-action tilting cylinders – even in winter.

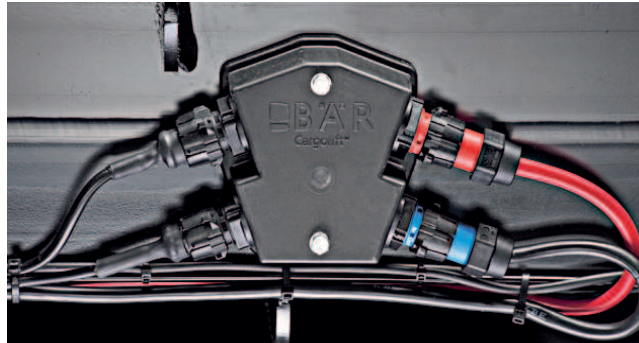

VDHH electrical interface (standard) for simple electrical connection.

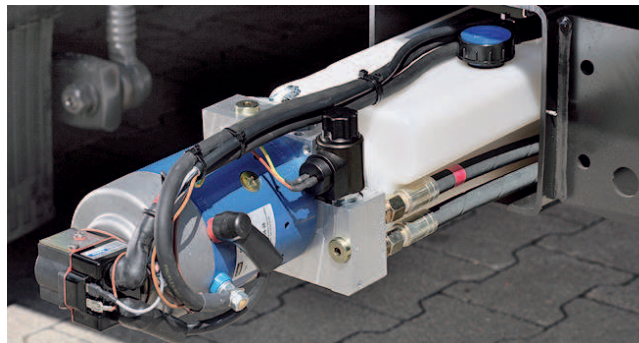

Power pack and control unit are safely protected in the beam (standard). Motor with thermal circuit breaker protecting against overheating and fire. Simple emergency operation of the four basic functions by push-button. **Low-noise power pack** (option) available.



Standard **hydraulic oil** requires annual oil change before the winter. For longer oil change interval (every 3 years) as well as for use at low temperatures of up to -45°C: Biodegradable **Syntofluid oil** (option).

Bär Cargolift Falt Equipment



Platform



Natural **aluminium** rear platform side (standard). **Anodised** platform (option) available.

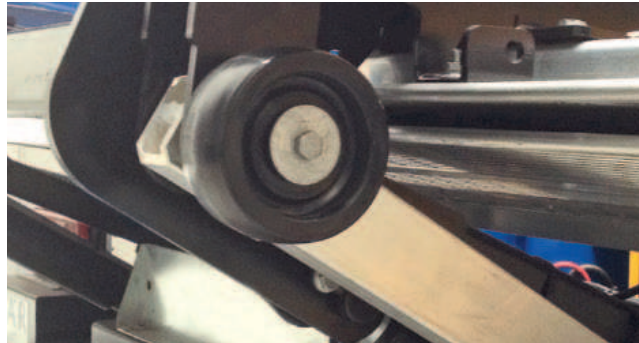

Ground rollers (standard) protect the platform from mechanical abrasion with ground contact.

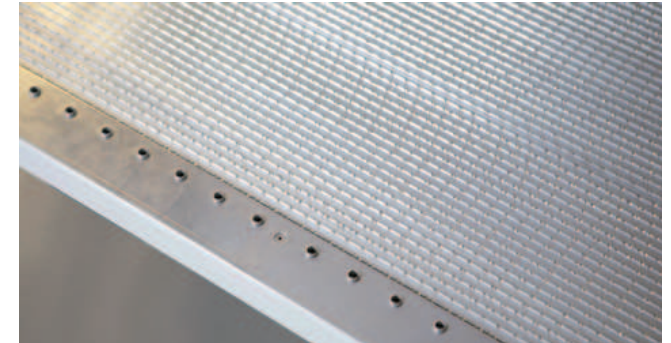

More safety and more traction on the platform with the **TracGrip** and **SideGrip** anti-slip platform surfaces (standard, R11) – even with wet surface. **TracGrip Plus** is optionally available with increased R13 anti-slip resistance.



User-friendly manual folding of platform package and platform tip with **spring relief** (standard).



Durable **CargoFlash** LED flashing light (standard) with high light intensity and very good sidewise emission with low current consumption.



Bär **SilentGrip** (option, R11) for increased noise insulation during night-time or morning deliveries in residential areas.

Bär Cargolift Falt Equipment



Platform

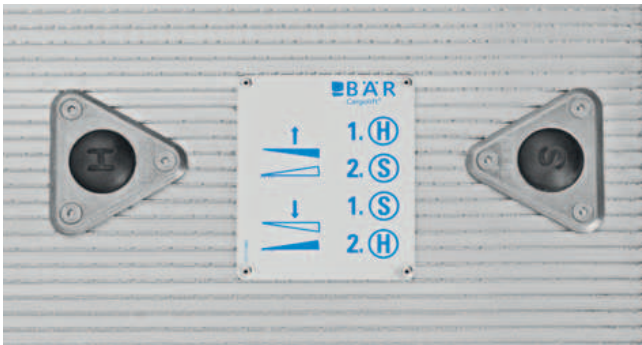

Bär **foot control** (standard) offers simple operation by means of two foot switches in addition to a safe location.

Platform trolley stops (option)

Bär Cargolift offers various **trolley stops** depending on the platform system which is in use. All trolley stops are distinguished by the highest roll-over resistance thanks to a double floor. Operating levers are always outside of the operating range.

For Falt Cargolifts, Bär offers the **trolley stops 2rd and 2ad**, which enable two switching positions by means of operating lever.

Position (1) - Loading - flap opens automatically after being driven over with trolleys

Position (2) - Unloading - flap locks after tramping down

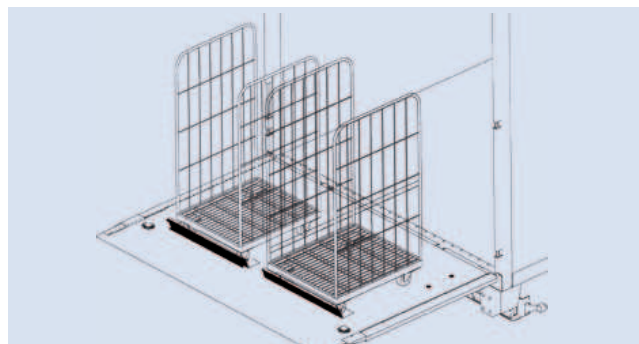

Trolley stops 2rd and 2ad enable the simultaneous transport of two trolleys. The trolley stop flaps open individually.

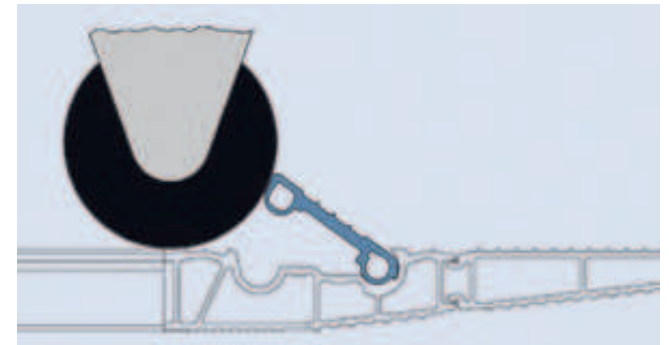

Trolley stop rd as a barrier for rollers with an opening angle of 43° for roller diameter up to 110 mm. Flap width: 750 mm with min. platform width of 2250 mm.

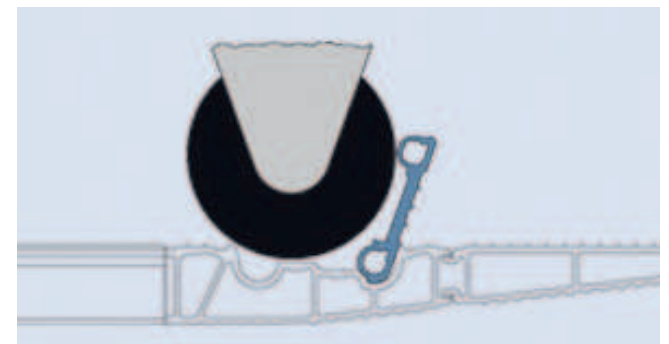

Trolley stop ad as a recess for rollers with an opening angle of 110° for roller diameter up to 200 mm. Flap width: 750 mm with min. platform width of 2250 mm.

Bär Cargolift Falt Equipment



Control elements



Bär Control EVO (standard) is intuitive in use, durably constructed and can be easily operated with gloves thanks to the vertically and horizontally operating joysticks.



Protection cover (option) for Bär Control EVO made of stainless steel.



Bär SmartControl Basic (option) for CE-compliant operation of all four basic functions by radio.

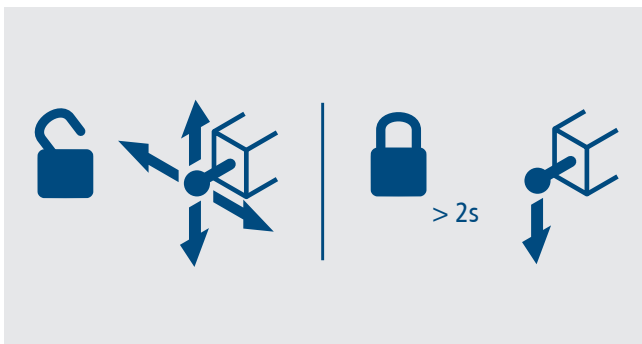

SwitchKey (option) enables the Cargolift to be switched on and off with the control lever, thus preventing any undesired operation.



External electrical key switch (option) for mounting on control box holder. Prevents any undesired operation as an alternative to the SwitchKey.



Bär SmartControl Plus with docking station (option) incl. remote control for recharging the accumulators (in place of batteries). Cabin switch can be operated via radio.

Bär Cargolift Falt Equipment



Control elements

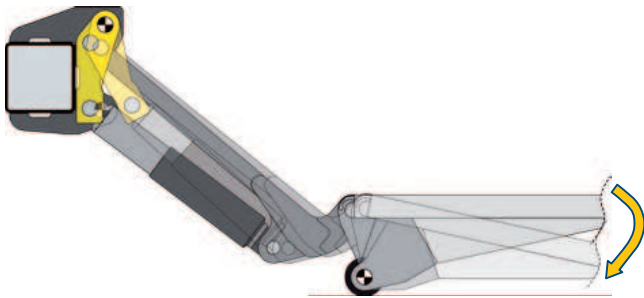

Gentle set-down with automatic tilt down on the ground (standard) for safe loading. The platform returns to its original position when tilting up by means of memory effect.



Pushbutton plate with 2 functions (option) for fitment inside the body.

Bär Cargolift – Lifting Performance.

The world of transport and logistics is becoming more and more competitive and complex. In order to work successfully in this business, customer oriented solutions with maximum efficiency are required. And last but not least high performance tail lifts.

Bär considers the tail lift as an integral part of an overall system which is being optimized user specifically to maximum performance. Only with a deep understanding of the various transportation tasks an ideal product solution can be created.

The core competence of Bär Cargolift is the continuous enhancement of the performance of tail lifts.

The customer of Bär Cargolift can be sure to receive a solution that supports his work in an optimal way. He gets supported in all phases of the product life cycle from ordering to mounting and from handling to service – based on partnership.

Bär Cargolift has shaped the industry over decades with innovative solutions. Solid technology that can be used easily and safely has created the decisive advance versus the competition.

Bär Cargolift – Lifting Performance.



Find out more about “Bär Cargolift – Lifting Performance. Since 1981.” – the family business, its innovations and its continuous development at: www.lifting-performance.com



Bär Cargolifts comply with the CE-Norm



Gerd Bär GmbH · Industriegebiet Böllinger Höfe · Pfaffenstraße 7 · D 74078 Heilbronn
Fon +49 7131 2877-992 · Fax +49 7131 2877-912 · vk@baer-cargolift.de · www.baer-cargolift.com