



Standard / FreeAccess for more payload

Bär Cargolift – Lifting Performance.

 **BÄR**  
Cargolift®

## Bär Cargolift Standard / FreeAccess Built for payload-optimised distribution transport



Open, closed, up, down – these options can be used to define the requirements on a taillift. After all, not every user intends to load five fully packed trolleys at the same time. Loading two trolleys on a platform in standard height is preferable. Or one pallet with a forklift. So much the better, when the remaining payload of the carrier vehicle allows for additional goods.

Therefore Bär offers for the low and medium payload market segment relatively low platforms and for standardised bodies the light, yet sturdy Standard / FreeAccess Cargolifts. The key factor is the 2=4 technology as well as the further weight-optimised development of the proven S4 products. Because stable and at the same time light Cargolifts are the ideal companions for the light vehicle class.

# Bär Cargolift Standard / FreeAccess

## More payload for light to medium vehicle classes



### 2=4 – How can one lifting and tilting cylinder be enough?

In addition to the powerful cylinder, Standard S2 / FreeAccess A2L Cargolifts have an equalisation mechanism in the lifting arm. With S2 and A2L Cargolifts with an under run bar that moves with the lift – BC 750 S2L/S / A2L and BC 1000 S2 – the transmission of force takes place over the equalisation mechanism and the under run bar, which deforms elastically. In this manner, compensation can be made for the asymmetry determined by the system.

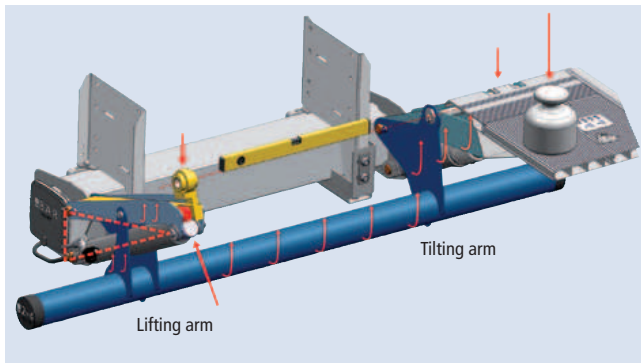

Adjustment mechanism and force transmission for Standard S2 / A2L Cargolifts with movable under run bar

### The light to medium vehicle class

Transporters with a permissible total gross weight of up to 6.5 t have a number of different chassis. They are usually fitted with Cargolifts with a load capacity of 750 kg. Bär Cargolift offers the following for this segment:

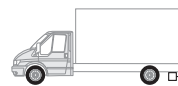

S2L/S / A2L with an under run bar that moves with the lift  
S4 with a fixed under run bar



A2L with a foldable FreeAccess platform

The payload-optimised Standard S2 / S4L Cargolifts with a load capacity of 1000 kg and 1500 kg are available for medium-weight trucks with a permissible total gross weight of up to 18 t:



S2 / S4L for medium-weight trucks

Standard / FreeAccess Cargolifts are designed to accommodate these loads in consideration of the platform height.

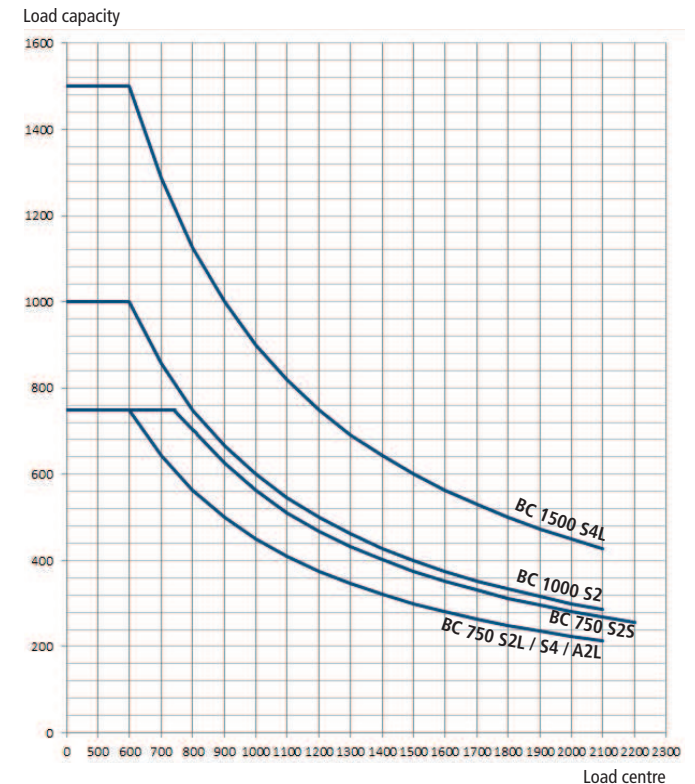

Load diagram of product group Standard / FreeAccess



Website with product movie



# Bär Cargolift Standard / FreeAccess – 750 kg

## BC 750 S2L – Light, lighter, S2L



Payload is the key topic in light vehicle classes in particular. The BC 750 S2L therefore makes you an attractive offer: It lifts 750 kg with a load centre of 600 mm and thereby adds just 160 kg to the scales (platform 1410 mm x 2100 mm). For what will you utilise the 20 kg gained here?

Carrier vehicle	GVW/t min.	GVW/t max.
Truck	3,5 t	8,0 t

Load capacity	Load centre	Load moment
750 kg	600 mm	4,5 kNm

### Aluminium platform

Platform system	Height	Width
BAplan30VLL	1210-1810 mm	1950 / 2520 mm

### Weight with platform width 2100 mm

Platform height	Weight
1410 mm	160 kg
1610 mm	167 kg
1810 mm	174 kg

The weight includes the standard scope of supply with mounting material and under run bar. Additional, mounting adapters which may be required are not included.

### Technical data

The following drawing shows installation on U-profile frames. Other frame profiles (e.g. hat profile) may require installation adapters (optional) – see vehicle connection equipment.

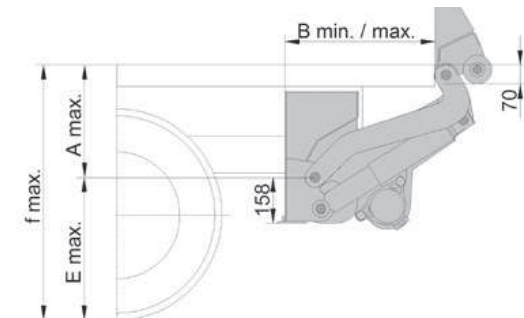

Arm length	575 mm	650 mm
Lifting height $f_{max}$	1020 mm	1120 mm
Mass $A_{max}$	480 mm	530 mm
Mass $E_{max}$	540 mm	590 mm
Clearance $B_{min}$	440 mm	485 mm
Clearance $B_{max}$	540 mm	625 mm

See fitment drawing for fitment details.

Only available as a 12V version.

# Bär Cargolift Standard / FreeAccess – 750 kg BC 750 S2S – The powerful Cargolift in the lightweight segment



Do you move heavy loads with your truck with a total gross weight of 3,5 t to 6,5 t? We offer you strong support for loading and unloading: BC 750 S2S. As of model year 2019, this Cargolift will offer even more durability and a load centre of 750 mm with unchanged net weight in comparison with BC 750 S2.

Carrier vehicle	GVW/t min.	GVW/t max.
Truck	3,5 t	8,0 t

Load capacity	Load centre	Load moment
750 kg	750 mm	5,6 kNm

### Aluminium platform

Platform system	Height	Width
BAplan30VL	1410-2210 mm	1950 / 2520 mm

### Weight with platform width 2010 mm

Platform height	Weight
1410 mm	186 kg
1610 mm	194 kg
1810 mm	202 kg

The weight includes the standard scope of supply with mounting material and under run bar. Additional, mounting adapters which may be required are not included.

### Technical data

The following drawing shows installation on U-profile frames. Other frame profiles (e.g. hat profile) may require installation adapters (optional) – see vehicle connection equipment.

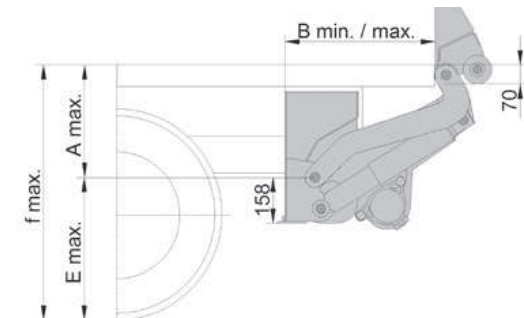

Arm length	575 mm	650 mm
Lifting height $f_{max}$	1020 mm	1120 mm
Mass $A_{max}$	480 mm	530 mm
Mass $E_{max}$	540 mm	590 mm
Clearance $B_{min}$	440 mm	485 mm
Clearance $B_{max}$	540 mm	625 mm

See fitment drawing for fitment details.

# Bär Cargolift Standard / FreeAccess – 750 kg

## BC 750 S4 – With fixed underrun bar and four cylinders



The BC 750 S4 has a fixed underrun bar, into which a towing bracket for ball coupling can be easily and economically integrated. In contrast to the alternative Cargolifts with a load capacity of 750 kg, the BC 750 S4 has four cylinders. The basic lifting mechanism is mounted using vehicle-specific fitment kits.

Carrier vehicle	GVW/t min.	GVW/t max.
Truck	3,5 t	8,0 t

Load capacity	Load centre	Load moment
750 kg	600 mm	4,5 kNm

### Aluminium platform

Platform system	Height	Width
BAplan30VLL	1610-2210 mm	1950 / 2520 mm

### Weight with platform width 2100 mm

Platform height	Weight	Weight with KKK
1610 mm	230 kg	244 kg
1810 mm	238 kg	252 kg

The weight includes the standard scope of supply with fitment kit for U frame, cables and under run bar.

### Technical data

The following drawing shows installation on U-profile frames. Other frame profiles (e.g. hat profile) may require installation adapters (optional) – see vehicle connection equipment.

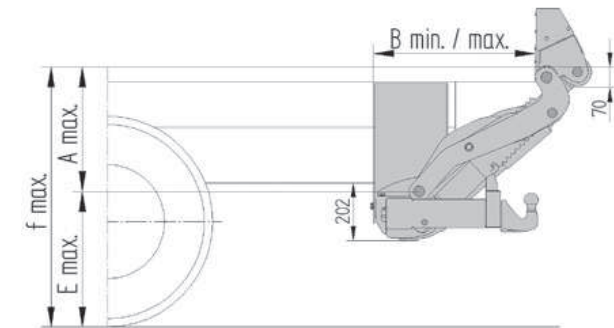

Arm length	600 mm
Lifting height $f_{max}$	1085 mm
Mass $A_{max}$	535 mm
Mass $E_{max}$	550 mm
Clearance $B_{min}$	642 mm
Clearance $B_{max}$	888 mm

See fitment drawing for fitment details.



# Bär Cargolift Standard / FreeAccess – 750 kg

## BC 750 A2L – The flexible solution for the light truck class



Powerful in use and equipped by standard with specific additional equipment, this concept conceals significantly more know-how than you would assume at first glance: Free access to the rear with the clever Bär FreeAccessStep, a large platform which you can use to transport a pallet or two food trolleys on demand. Everything is provided in an extremely stable, light-weight design.

Carrier vehicle	GVW/t min.	GVW/t max.
Truck	3,5 t	8,0 t

Load capacity	Load centre	Load moment
750 kg	600 mm	4,5 kNm

### Aluminium platform

Platform system	Height	Width
BAplan30VLL	1630 mm	1780 mm

### Weight with platform width 1780 mm

Platform height	Weight
1630 mm	194 kg

The weight includes the standard scope of supply with mounting material, cables and under run bar. Additional, mounting adapters which may be required are not included.

### Technical data

The following drawing shows installation on U-profile frames. Other frame profiles (e.g. hat profile) may require installation adapters (optional) – see Vehicle connection equipment.

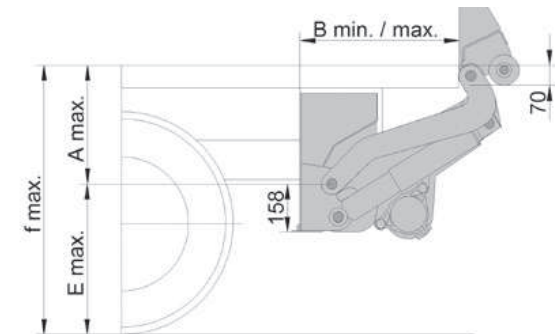

Arm length	575 mm	650 mm
Lifting height $f_{max}$	1030 mm	1140 mm
Mass $A_{max}$	490 mm	550 mm
Mass $E_{max}$	540 mm	590 mm
Clearance $B_{min}$	395 mm	440 mm
Clearance $B_{max}$	465 mm	520 mm

See fitment drawing for fitment details.

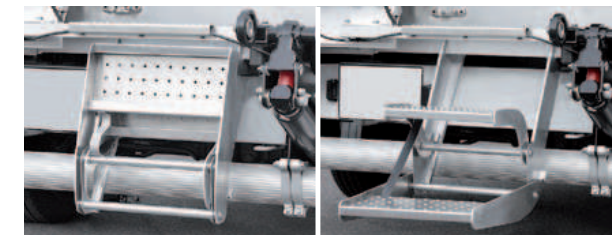

**FreeAccessStep** (option) made of anodised aluminium can be unfolded with a handle and offers the best footing thanks to wide steps and grip surface. Weight approx. 15 kg. Cannot be combined with a towing bracket for ball coupling.

# Bär Cargolift Standard / FreeAccess – 750 kg Equipment



## Lifting unit

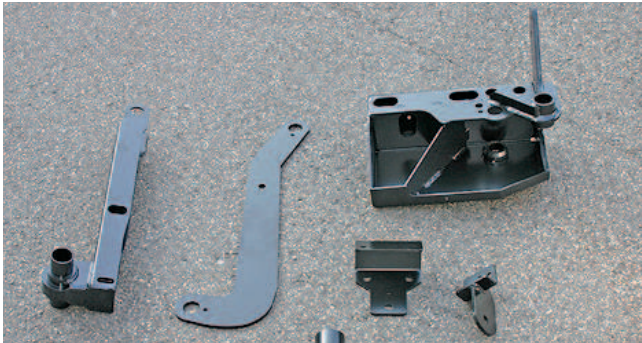

**Cathodic dip coating** (RAL 9005 – standard) of all steel parts as long-term anti-corrosive protection with out additional top coat. With frequent cleaning of the vehicle, **cathodic dip coating + powder coating** (optional) in RAL colour of your choice.



**VDHH electrical interface** (standard) for simple electrical connection.

## Platform



Natural **aluminium** rear platform side (standard S2/S4) or powder-coated in RAL colour of your choice (option S2/S4) and **anodised** platform (option S2 / S4) available.

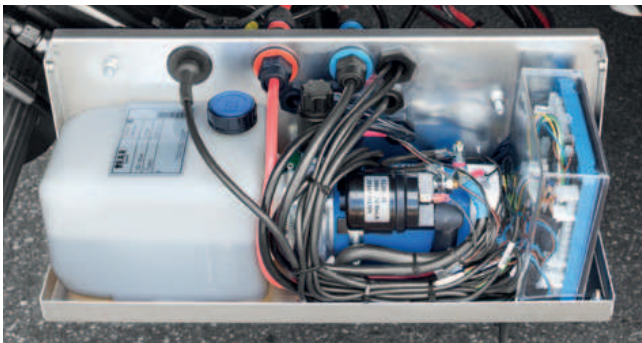

Motor and control unit are housed for easy access in the **power pack case**. Motor with thermal circuit breaker protecting against overheating and fire. Simple **emergency operation** of the four basic functions by pushbutton (standard).



Standard **hydraulic oil** requires annual oil change before the winter. For longer oil change interval (every 3 years) as well as for use at low temperatures of up to -45°C: Biodegradable **Syntofluid oil** (option).



Rear platform side **powder-coated** in RAL 9006 white aluminium. **Anodised** platform edging (standard A2L).



# Bär Cargolift Standard / FreeAccess – 750 kg Equipment



## Platform

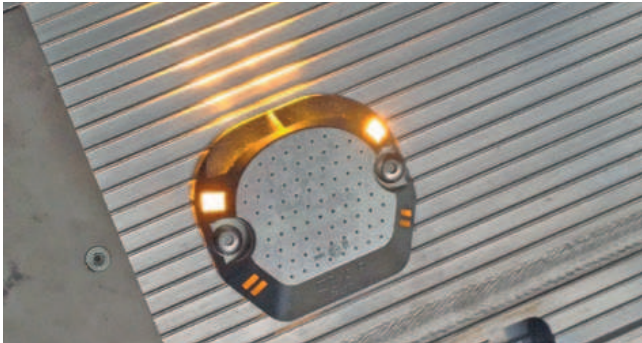

Durable **CargoFlash** LED flashing light (standard) with high light intensity and very good sidewise emission with low current consumption.

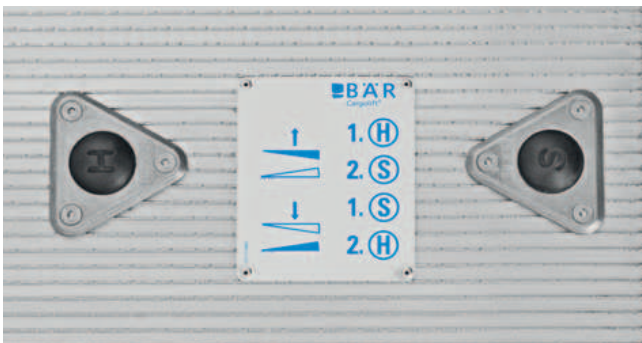

Bär **foot control** (standard) offers simple operation by means of two foot switches in addition to a safe location.

## Platform – trolley stops (option)

Bär Cargolift offers various **trolley stops** depending on the platform system which is in use. All trolley stops are distinguished by the highest roll-over resistance thanks to a double floor. Operating levers are always outside of the operating range.

For Standard Cargolifts, Bär offers the **trolley stops 2rd and 2ad**, which enable two switching positions by means of operating lever.

Position (1) - Loading - flap opens automatically after being driven over with trolleys

Position (2) - Unloading - flap locks after tramping down

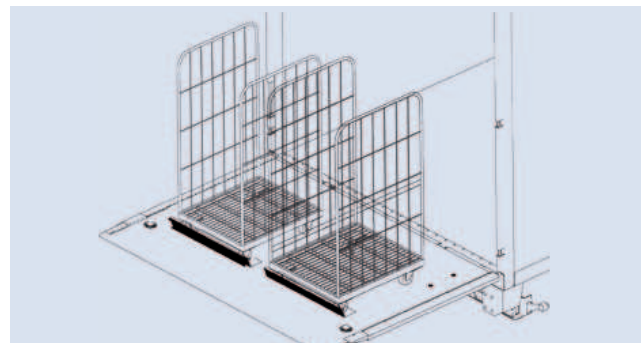

**Trolley stops 2rd and 2ad** enable the simultaneous transport of two trolleys. The trolley stop flaps open individually.

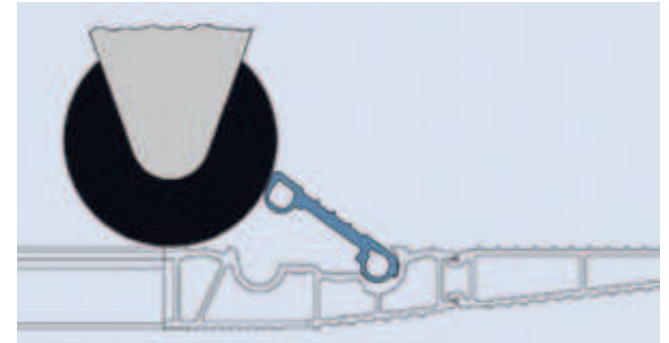

**Trolley stop rd** as a barrier for rollers with an opening angle of 43° for roller diameter up to 110 mm. Flap width: 750 mm (S2 / S4) with min. platform width of 1950 mm, 850 mm (S2) with min. 2150 mm.

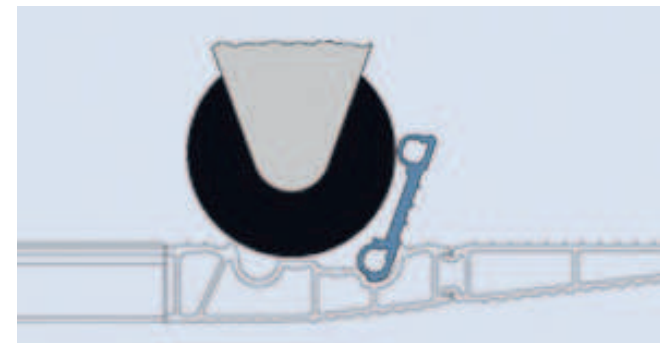

**Trolley stop ad** as a recess for rollers with an opening angle of 110° for roller diameter up to 200 mm (standard A2L). Flap width: 750 mm (S2 / S4) with min. platform width of 1950 mm, 850 mm (S2 / S4) with min. 2150 mm, 650 mm (A2L).

# Bär Cargolift Standard / FreeAccess – 750 kg Equipment



## Platform

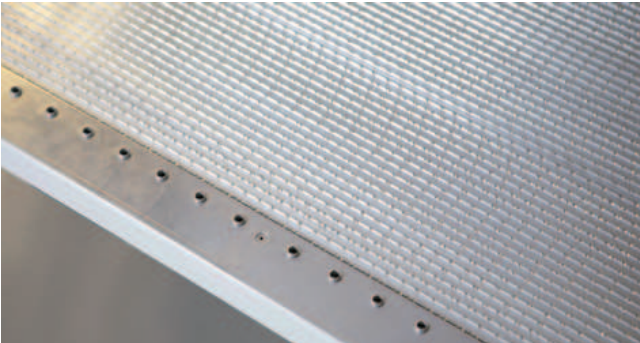

More safety and more traction on the platform with the **TracGrip** and **SideGrip** anti-slip platform surfaces (standard, R11) – even with wet surface. **TracGrip Plus** is optionally available with increased R13 anti-slip resistance.



Bär **SilentGrip** (option S2 / S4, R11) for increased noise insulation during night-time or morning deliveries in residential areas.



**CargoSeal** sealing system (option S2 / S4) for reliable rear end closure with body-closing platform.



Bär **CargoBridge** (option) for fitment of platform behind doors with twist locks.

## Control elements

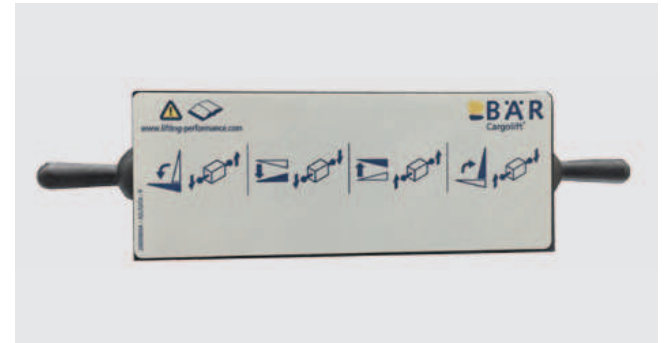

**Control box** (standard) for operation of four basic functions of the Cargolift.

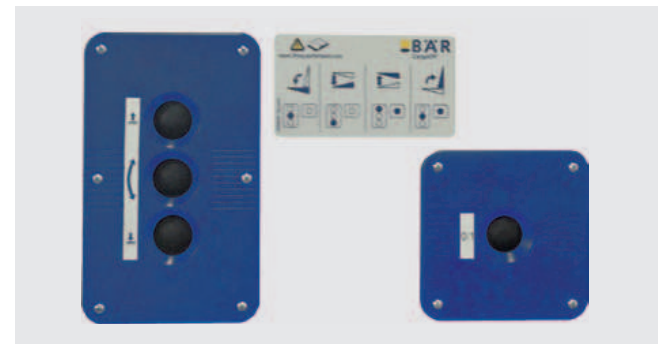

**Pushbutton plate 3+1** (option) for mounting outside in the body wall.

# Bär Cargolift Standard / FreeAccess – 750 kg Equipment



## Control elements



**Bär Control EVO** (option) is intuitive in use, durably constructed and can be easily operated with gloves thanks to the vertically and horizontally operating joysticks. Platform tilt angle can be saved with the right control lever.



**Bär SmartControl Basic** (option) for CE-compliant operation of all four basic functions by radio.



**Wander lead** (option) with two functions incl. platform marking for the assigned operating position. Socket for wander lead pre-fitted on the control box or for mounting in the body.

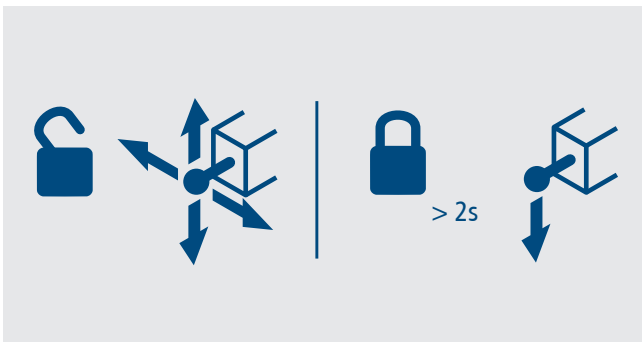

**SwitchKey** (option for Bär Control EVO) enables the Cargolift to be switched on and off with the control lever. Alternatively, an **external electrical key** switch (option) can be mounted.



**Bär SmartControl Plus with docking station** (option) incl. remote control for recharging the accumulators (in place of batteries). Cabin switch can be operated via radio.



**Pushbutton plate with 2 functions** (option) for fitment inside the body.



# Bär Cargolift Standard S2 / FreeAccess A2L – 750 kg Equipment



## Vehicle connection



**Adapter plate BC 750 S2L/S / A2L** made of aluminium. Required for mounting on the following vehicles.

Carrier vehicle	Adapter plate S2L / S2S / A2L	Fitment kits BC 750 S4	Towing bracket ball coupling	
			S2L / S2S / A2L	S4
Mercedes-Benz Sprinter	approx. 10 kg	approx. 10 kg	approx. 60 kg	approx. 14 kg
Volkswagen Crafter / MAN TGE	approx. 10 kg	approx. 12 kg	approx. 60 kg	
Iveco Daily / Renault Mascott	without	approx. 6 kg	approx. 50 kg	
Ford Transit	approx. 12 kg	approx. 12 kg	approx. 60 kg	
Renault Master / Opel Movano B / Nissan NV400	approx. 14 kg	approx. 13 kg	approx. 60 kg	
Fiat Ducato / Peugeot Boxer / Citroën Jumper / Opel Movano C	approx. 10 kg	approx. 12 kg	approx. 60 kg	
Renault Maxity / Fuso Canter / Isuzu	without	approx. 6 kg	approx. 50 kg	
Nissan Atleon / Cabstar / Interstar / Toyota Dyna / Renault Maxcity	–	approx. 6 kg	–	



Towing bracket for ball coupling S2L / S2S / A2L

**Towing bracket for ball coupling** (option) with European type approval for the parts (parts ABE), D-value 19.9 kN, weight approx. 45 kg for S2L/S/A2L and approx. 14 kg for S4. Advance electrical preparation required on the vehicle!

**Ball coupling** optionally available.

Calculation of the maximum admissible trailer load of the towing bracket:

$$\text{trailer load in t} = \frac{\text{D-value in kN} \times \text{GVW vehicle in t}}{(9,81 \text{ m/s}^2 \times \text{GVW vehicle in t}) - \text{D-value in kN}}$$

In case the carrier vehicle or the ball coupling lead to a lower admissible trailer load, the lowest value is determining.



Towing bracket for ball coupling S4

# Bär Cargolift – Lifting Performance.

The world of transport and logistics is becoming more and more competitive and complex. In order to work successfully in this business, customer oriented solutions with maximum efficiency are required. And last but not least high performance tail lifts.

Bär considers the tail lift as an integral part of an overall system which is being optimized user specifically to maximum performance. Only with a deep understanding of the various transportation tasks an ideal product solution can be created.

The core competence of Bär Cargolift is the continuous enhancement of the performance of tail lifts.

The customer of Bär Cargolift can be sure to receive a solution that supports his work in an optimal way. He gets supported in all phases of the product life cycle from ordering to mounting and from handling to service – based on partnership.

Bär Cargolift has shaped the industry over decades with innovative solutions. Solid technology that can be used easily and safely has created the decisive advance versus the competition.

## Bär Cargolift – Lifting Performance.



Find out more about “Bär Cargolift – Lifting Performance. Since 1981.” – the family business, its innovations and its continuous development at: [www.lifting-performance.com](http://www.lifting-performance.com)



Bär Cargolifts comply with the CE-Norm



Gerd Bär GmbH · Industriegebiet Böllinger Höfe · Pfaffenstraße 7 · D 74078 Heilbronn  
Fon +49 7131 2877-992 · Fax +49 7131 2877-912 · vk@baer-cargolift.de · www.baer-cargolift.com